

**003 Series
Switch Box**

Installation Operation Maintenance



General

003 Series Switch box is designed to directly mount on Actuators having top mounting accordings to NAMUR VDE-3845.

Installation

003 series switch box is mounted onto the actuator using a bracket fixed to the box with 4 M5x12 Star head screws or hexagonal head bolts or Socket head screws and connected to the actuator with 4 M5x12 Star head screws.

During assembly pay attention that the tongue fits perfectly the penion shaft.

KENWOOD VALVE CONTROLS (INDIA) PRIVATE LIMITED

A. Wiring for Mechanical microswitches

Remove the cover after unscrewing 4 screws. Remove the plastic plugs from the cable entries and substitute the plastic plugs with adequate cable glands to ensure the watertight seal. Unused cable entry shall be plugged with metal plug of equal IP protection as of Limit switch box to ensure watertight seal.

A wiring diagram is printed onto the PCB inside the switch box adjacent to terminals. Follow it carefully for right connection to your system. Size the cable according to the application.

Solenoids may also be wired through the switch box (applicable when optional Solenoid terminals are provided).

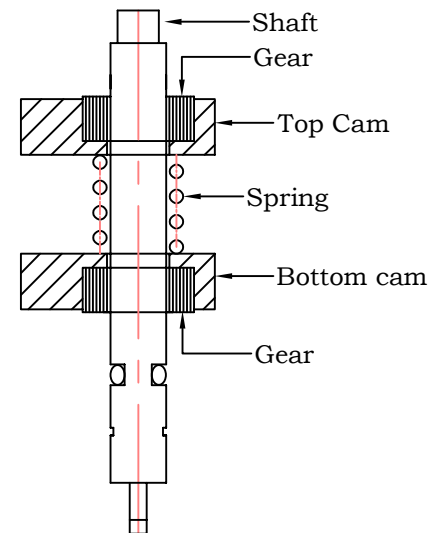

Adjusting limit switches

WARNING: disconnect power before removing cover!

Normally the switches are factory set for 90 degree (open/close) and does not need any further setting. If required, follow the procedure given below:

1. Make the Actuator/Valve rotate counter clockwise - For OPEN Switch setting.

Push the YELLOW TOP cam (for open switch) to disengage it from gear, and rotate it until switch trips (Hold the switch roller pressed for proper cam alignment while setting the cam, in case of mechanical switches).

2. Make the Actuator/Valve rotate clockwise - For CLOSE Switch setting. Pull the RED BOTTOM cam (for close switch) to disengage it from gear, and rotate it until switch trips (Hold the switch roller pressed for proper cam alignment while setting the cam, in case of mechanical switches).

Dimensions

L x W x H = 122 x 82 x 105 mm

Weight - 563g (1NO+1NC); 680g (2NO+2NC).

The information is subject to change without notice.

Shed No. C217, M.T. Sagar,
Industrial Estate,
Gokul Road,
HUBLI-580 030 (INDIA).

TeleFax: +91-836-2232118

Mobile: +91-7349132241

e-mail: preorders@kenwoodvalvecontrols.com

B. Wiring for Rectangular Proximity sensor

Remove the cover after unscrewing 4 screws. Remove the plastic plugs from the cable entries and substitute the plastic plugs with adequate cable glands to ensure the watertight seal. Unused cable entry shall be plugged with metal plug of equal IP protection as of Limit switch box to ensure watertight seal.

A wiring diagram is printed onto the PCB inside the switch box adjacent to terminals. Follow it carefully for right connection to your system. Size the cable according to the application.

Solenoids may also be wired through the switch box (applicable when optional Solenoid terminals are provided).

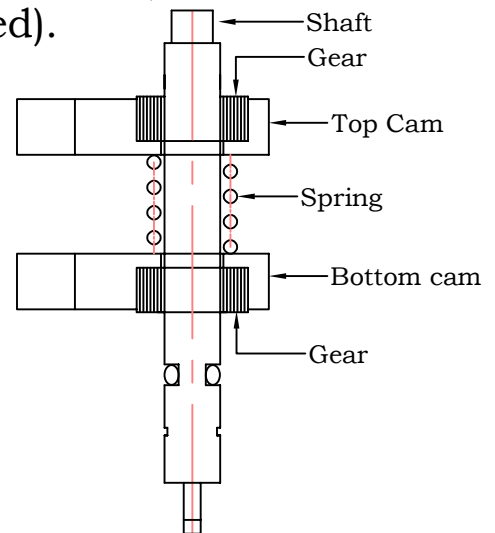

Adjusting limit switches

WARNING: disconnect power before removing cover!

Normally the switches are factory set for 90 degree (open/close) and does not need any further setting. If required, follow the procedure given below:

1. Make the Actuator/Valve rotate counter clockwise-For OPEN Sensor setting.

Push the YELLOW TOP cam (for open sensor) to disengage it from gear, and rotate it until sensor target is close to sensor. Re-engage the cam with gear.

2. Make the Actuator/Valve rotate clockwise-For CLOSE Switch setting.

Pull the RED BOTTOM cam (for close sensor) to disengage it from gear, and rotate it until sensor target is close to sensor. Re-engage the cam with gear.

Dimensions

L x W x H = 122 x 82 x 105 mm

Weight-563g(2no sensors); 680g(4no sensors).

The information is subject to change without notice.

Shed No.C217,M.T. Sagar,
Industrial Estate,
Gokul Road,
HUBLI-580 030(INDIA).

TeleFax:+91-836-2232118

Mobile:+91-7349132241

e-mail:preorders@kenwoodvalvecontrols.com

KENWOOD VALVE CONTROLS (INDIA) PRIVATE LIMITED

C. Wiring for Cylindrical proximity sensor (For Rotary Actuator)

Remove the cover after unscrewing 4 screws. Remove the plugs from the cable entries and substitute them with adequate cable glands to ensure the watertight seal. Unused cable entry shall be plugged with metal plug to ensure watertight seal.

A wiring diagram is printed onto the PCB inside the switch box adjacent to terminals. Follow it carefully for right connection to your system. Also refer the wiring diagram for a particular switch/sensor. Size the cable according to the application. Solenoid may also be wired through the switch box (applicable when optional Solenoid terminals are provided).

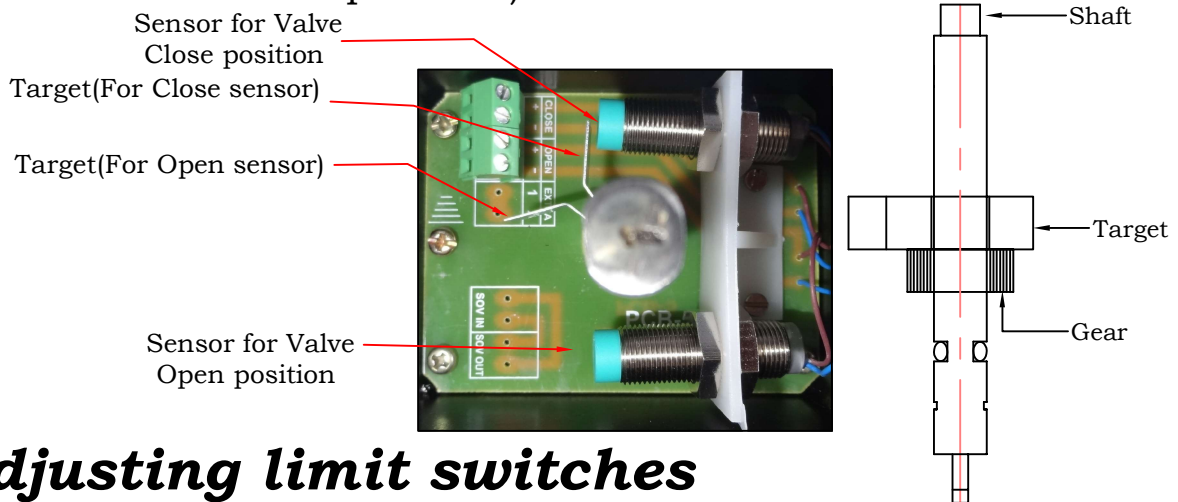

Adjusting limit switches

WARNING: disconnect power before removing cover!

Normally the switches are factory set for 90 degree (open/close) and does not need any further setting. If required, follow the procedure given below:

1. Make the Actuator/Valve rotate counter clockwise-For OPEN Switch setting. Push/rotate the target until one side of target comes close to the open side sensor (either it can touch the sensor or maintain a very small gap of 1mm between sensor and target).

2. Make the Actuator/Valve rotate clockwise-For CLOSE Switch setting. Check whether the other side of target is close to the close side sensor (either it can touch the sensor or maintain a very small gap of 1mm between sensor and target). If not move the sensor, such that either it touches the target or a very small gap of 1mm between sensor and target is maintained without pushing/rotating the target. Once again the check for open position also, after setting for close position.

Dimensions

L x W x H = 122 x 82 x 105 mm

Weight-563g(2no sensors)

The information is subject to change without notice.

Shed No.C217, M.T. Sagar,
Industrial Estate,
Gokul Road,
HUBLI-580 030(INDIA).

TeleFax:+91-836-2232118

Mobile:+91-7349132241

e-mail:preorders@kenwoodvalvecontrols.com

KENWOOD VALVE CONTROLS (INDIA) PRIVATE LIMITED

Wiring Diagram

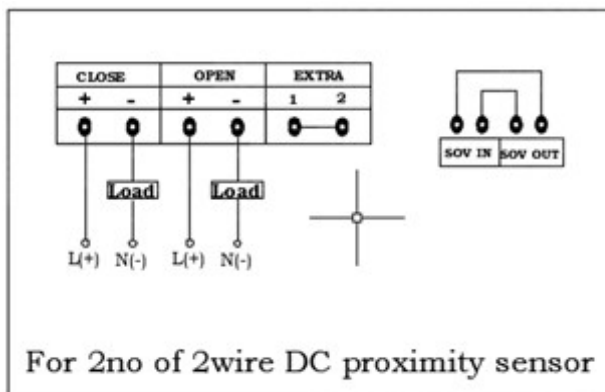
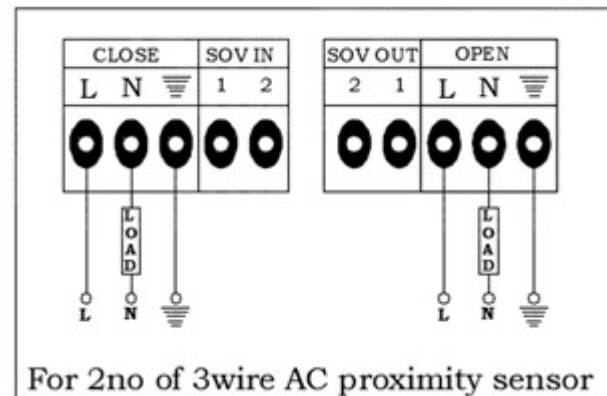
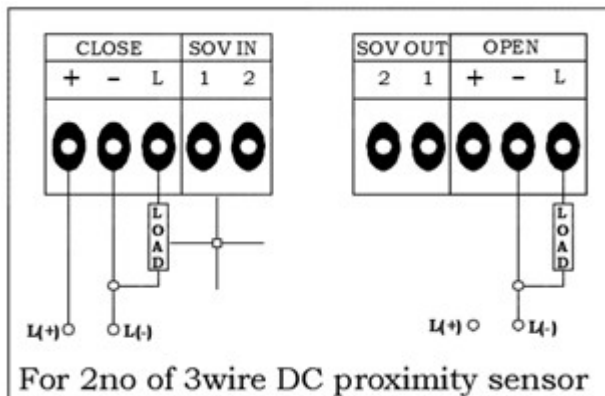
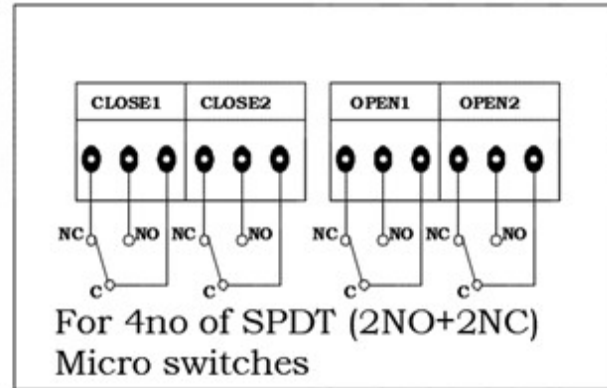
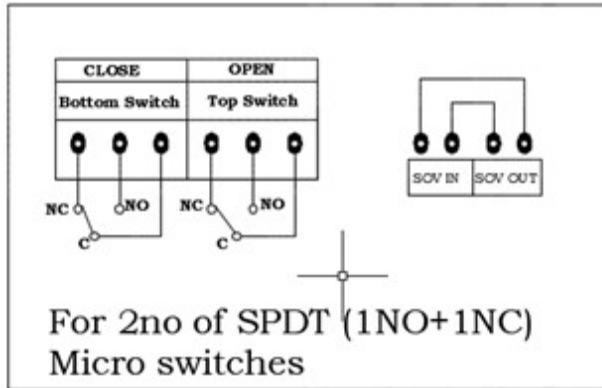

Note:

- >>C---Common terminal
- >>NO---Normally Open terminal
- >>NC---Normally Close terminal
- >>SOV IN---From Control room for Solenoid valve connection
- >>SOV OUT---To Solenoid valve connection
- >>L---Line
- >>N---Neutral
- >>Solenoid terminals are provide only when asked

Rated voltage/current:

Switch /sensor rated voltage and current depends on the switch / sensor used.
Test certificate provided with the product is to be referred for the same.